

Pure competence in air.

NOVENCO® NOVA™ AIR HEATERS VMA/VMB INSTALLATION AND MAINTENANCE

Building & Industry



SCHAKO Group

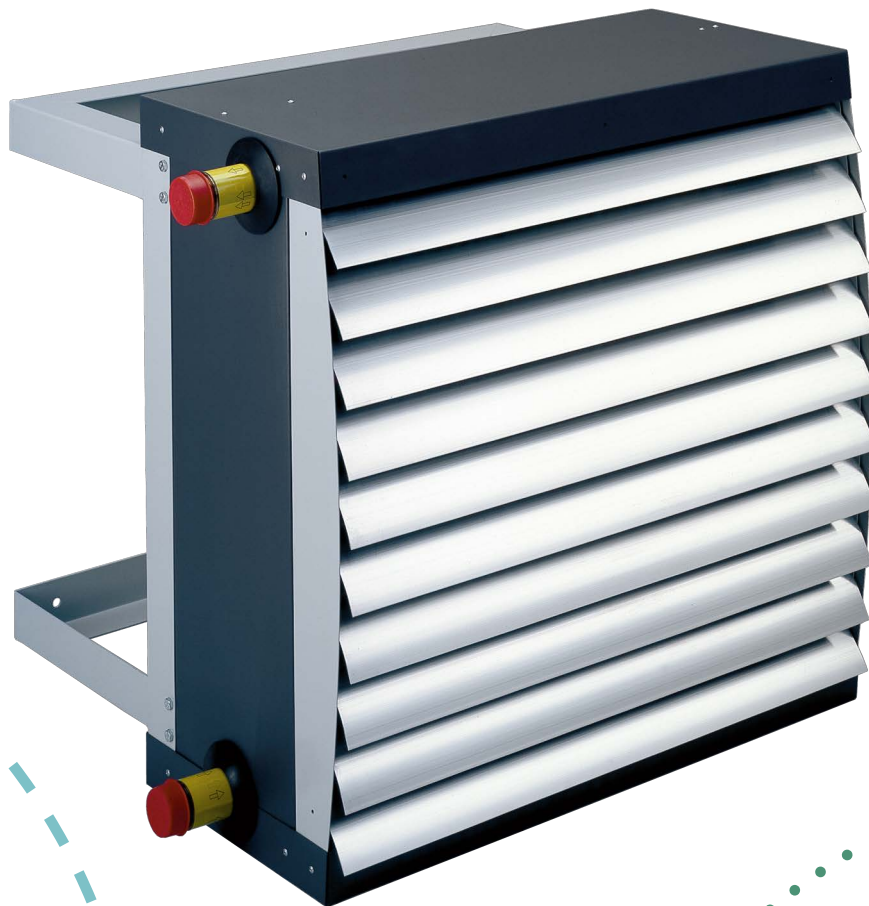

ENGLISH

918027-0

Novenco® NoVa™ air heaters type VMA and VMB

Installation and maintenance

Contents

1. Application

1.1 Reading guide

2. Product overview

2.1 Scope of delivery

2.2 Mounting positions

2.3 Storage

3. Installation

3.1 Assembly and mounting

3.2 Pipe circuit construction

3.3 Connection of heating medium

3.4 Regulation and frost protection

3.5 Electrical connections

4. Maintenance

4.1 Inspection

4.2 Cleaning

4.3 Impeller

4.4 Motor

4.5 Heating coil

4.6 Damper

4.7 Filter

4.8 Other components

5. Electrical connection

5.1 Motors

5.2 Regulators

5.3 Re-configuration of NV515 – 5-step

5.4 Wiring diagrams

6. Troubleshooting

7. Inspection and test

8. Sound

9. Safety

10. Disposal

11. Patents and trademarks

12. Quality management

13. Warranty

14. Spare parts

15. Product lifetime

16. Declaration of conformity

Appendices – wiring diagrams

A. Thermostats RDG100T and NV515

B. RDG100T – 5-step regulators

C. RDG100T – stepless regulator 2.5 A

D. RDG100T – stepless regulator 5 A

E. NV515 – 5-step regulators

F. NV515 – stepless regulator 2.5 A

G. NV515 – stepless regulator 5 A

1. Application

The Novenco NoVa air heaters type VMA and VMB are for heating of large areas such as industrial work zones, workshops, halls, warehouses, large sports centres etc.

1.1 Reading guide

This guide covers the installation and maintenance of Novenco NoVa air heaters type VMA and VMB as well as original accessories. Please study the guide and read sections relevant to the work at hand in full.



Icons	Description
	Risk of damage to equipment
	Risk of injury or death

Table 1. Icons in guide

2. Product overview

The air heater consists of a basic unit, which can be fitted with accessories for air distribution on the outlet side.

Legend for figure 1

1. Fan suspension and wire mesh
2. Motor and fan
3. Heating coil
4. Cabinet
5. Mounting brackets

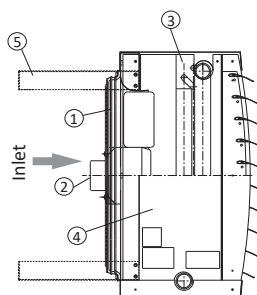

Figure 1. Basic unit

Legend for figures 2 and 3

1. Basic unit with fan and heating coil
2. Front grille J1 - with individually adjustable-louvres
3. Front grille J2 - with individually adjustable louvres in two directions
4. Mixing housing in three designs
 - B3, without damper, only for connection of return air
 - B13, with inter-connected dampers on top and bottom for fresh and return air
 - B23, with inter-connected dampers on the reverse side and bottom for fresh and return air
5. Return air duct
6. Filter section F
7. Fresh air duct - for intake of fresh air through roof
8. Fresh air hood H
9. Wall grille M - for intake of fresh air directly into the mixing housing
10. Air diffuser J4 - for horizontal air distribution in four directions with vertical supply
11. Air cone K - for jet-shaped air distribution in high-ceiling rooms.

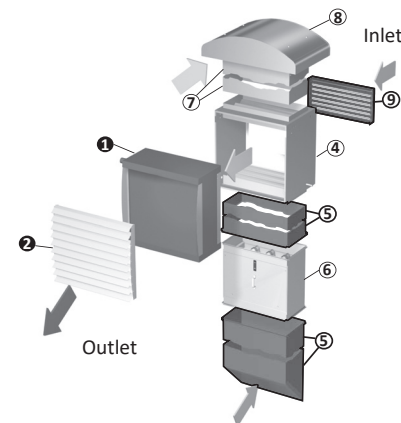

Figure 2. Horizontal position

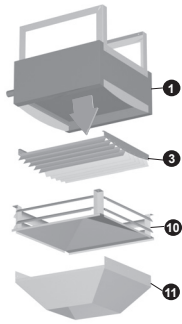

Figure 3. Vertical position

Accessories for recirculation and mixing of fresh and return air are mounted on the inlet side. The basic unit consists of a cabinet with heating coil and axial flow fan. The fan motor is on the inlet side. Pipe connections for the heating medium are on the cabinet side. The fan motor is fitted with 1.5 m cable. The VMA is for water from boilers or heat pumps with temperature drops of 10 to 20 °C. The VMB is for water from district-heating systems with temperature drops of 40 °C. Refer also to the technical calculation.

2.1 Scope of delivery

The basic unit and accessories are delivered in cartons. Ducting is outside the scope of delivery.

Included with the basic unit

- 2 mounting brackets for installations without accessories on the inlet side
- A drilling template for mounting brackets
- Self-tapping screws for mounting of accessories on the outlet side

If a Novenco mixing housing is part of the delivery, it comes with two mounting angles. These angles are screwed onto the open ends of the housing during transport. If a Novenco fresh air hood is part of the delivery, it comes with supporting fixtures and clamping

bolts for hood and duct.

Types	Weights [kg]
VMA/B 42-43	20
VMA/B 52-53	30
VMA/B 62-63	40
VMA/B 72-73	50
VMA/B 82-84	67

Table 2. Maximum weights of base units

2.2 Mounting positions

The units are for wall mounting (horizontal inlet) or roof mounting (vertical inlet) with optional location of the pipe connections for water on the vertical sides of the fan.

2.3 Storage

Store air heaters correctly to ensure function and durability.

 Damages due to incorrect storage void the warranty.

Conditions	Specifications	Comments
Outdoor	One month	<ul style="list-style-type: none"> • Packaging must be intact
Indoor or sheltered	Max. six months	<ul style="list-style-type: none"> • For unprotected air heaters with no or broken packaging • Ventilated location • No condensation
Prolonged	Max. two years	<ul style="list-style-type: none"> • Indoor • Remove packaging • Ventilated location • No condensation • Turn impeller 20 times every six months
Vibrations	No	<ul style="list-style-type: none"> • Location must be vibration free
Temperatures	-20 to 55 °C	<ul style="list-style-type: none"> • Constant temperature, preferably 20 °C • Ventilated • No condensation
Humidity	Below 70%	<ul style="list-style-type: none"> • Avoid condensation • Exceedance requires airtight packaging of complete air heater and use of a moisture absorbent agent such as silica gel

Table 3. Storage recommendations

3. Installation

3.1 Assembly and mounting

Before mounting, screw the air distribution accessories onto the

outlet of the basic unit using the supplied screws. The natural frequency of the surface the fans are mounted onto must be 20% higher than the fan speed.

Types	Frequency [Hz]	RPMs
VMA/B 42-43	50 / 60	1350 / 1490
VMA/B 52-53	50 / -	1300 / -
VMA/B 62-63		1320 / 1450
VMA/B 72-73	50 / 60	910 / 980
VMA/B 82-84		920 / 1080

Table 4. Fan RPMs

No accessories on inlet side – wall or ceiling mounting

1. Screw the mounting brackets onto the basic unit.

Eight screws for mounting in the corners of the unit on the inlet side are included. The position of the brackets is identical for both wall and ceiling mounting.

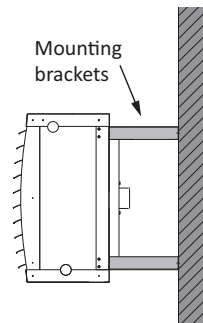

Figure 4. Wall mounting

2. Mark holes for mounting on the wall or ceiling surfaces using the included template sheet.

Note: The underside of wall-mounted units must be at least 2.2 m above the floor.

3. Drill holes for M8 size bolts.

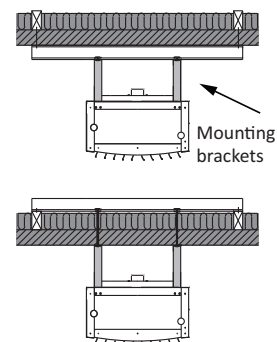

Figure 5. Ceiling mounting

- Lift the unit into position and support it.
- Tighten the fastening bolts and screws carefully.

For non-supporting ceilings M8 threaded rods with discs and nuts can be used for suspension in sectional frames attached to supporting parts.

A Novenco mixing housing and accessories on inlet side - wall mounting

- Mark holes for mounting on the wall surfaces using the included template sheet.
Note: Wall-mounted fans must be at least 2.2 m above the floor from the underside.
- Drill holes for M8 size bolts.
- Mount one of the two mounting angles on the wall to support the second bracket.

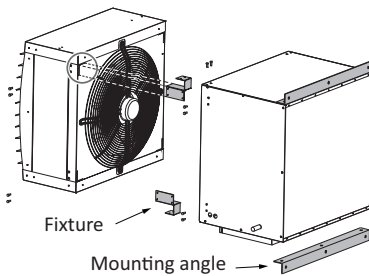

Figure 6. Mounting brackets for wall

- Secure the other mounting angle to the top plate of the mixing housing with the three screws.
- Remove the screws at the bottom of the mixing housing.
- Mark the three upper mounting holes on the wall using the mixing housing.
- Mount the mixing housing with the four supplied fixtures.
- Assemble the basic unit with the mixing housing using the supplied screws.
- Pull the motor cable through one of the cable inlets on the access side. See figure 6.
- Mount the entire unit on the wall in the upper mounting angle

- Re-insert the screws in the bottom plate of the mixing housing through the lower mounting angle.
- Push the connected ducts across the duct connections of the mixing housing.
- Attach the ducts by means of self-tapping screws.
The return air duct should be supported against the wall.
- Mount regulators on the damper shafts of the mixing housings.

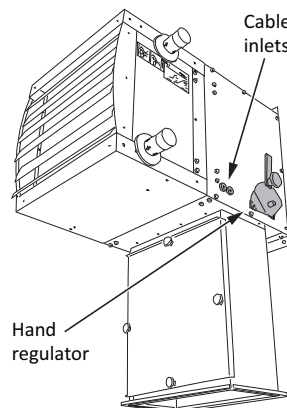

Figure 7. Wall-mounted unit

Manually operated hand regulators are mounted directly onto the shafts.

Motor-driven regulators for automatic operation are mounted onto the shafts according to the motor supplier's instructions.

A slot at the end of the damper shaft marks the position of the dampers plate. See figure 6.

- Mount the filter section in the return or fresh air duct with U-cleats.

Note: An arrow on the filter front should indicate the air direction.

A Novenco mixing housing and accessories on inlet side - ceiling mounting

- Assemble fan, mixing housing and mounting angles on the floor.
- Hoist the assembly into position.

M8 lifting eyes can be placed in the mounting brackets.

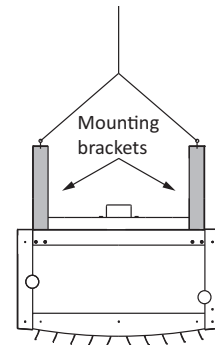

Figure 8. Hoisting air heater

- Attach the unit to the ceiling.

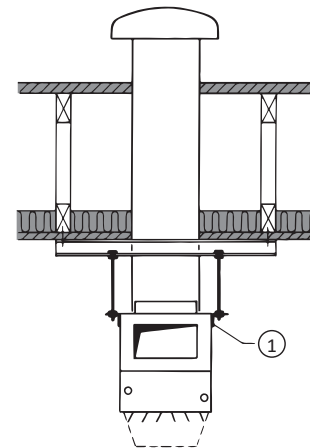

Figure 9. Ceiling mounting

- Mount the fresh air hood on top of the fresh air duct by means of the supplied supporting fixtures and stainless screws.

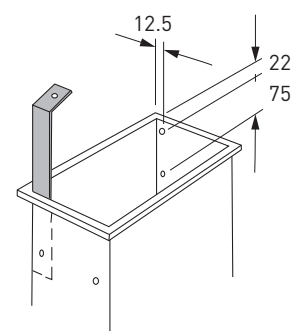

Figure 10. Mounting fresh air hood

The hood has mounting holes. Drill holes in the ducts when mounting.

3.2 Pipe circuit construction

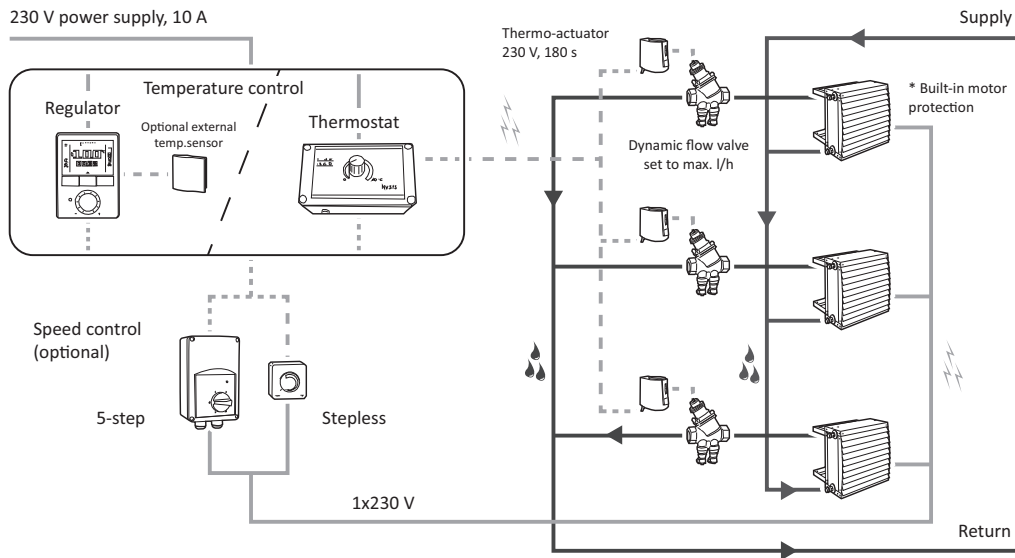

Figure 11. Basic system layout – pipe circuit and electric wiring

Review the basic system layout in figure 11. It shows the principle, which the implemented system should follow.

It is recommended to make a plan of both the pipe and the electrical circuits.

Construction stages

1. Connect the air heaters and flow valves to the heating medium as described in section “3.3 Connection of heating medium”.
2. Connect the regulation and frost protection. See section “3.4 Regulation and frost protection”.
3. Connect the electrical as described in section “3.5 Electrical connections”.
4. Test the system.

3.3 Connection of heating medium

The air heaters are designed for hot water as heating medium.

Heating media sources

- Boilers – type VMA
- Heat pumps – type VMA
- District heating – type VMB

Pipe connections are 5/4” pipe thread. The water flow direction is indicated on the pipe connections.

Check the orientation of the flow valves and set the maximum water flow rate. The flow rate can be calculated with the following formula.

$$Q_{\text{water}} = \frac{P}{\frac{\Delta_{\text{loss}}}{10 \text{ } ^\circ\text{C}} \times 42} \times 3600$$

Example

Heat need: 50 kW
Heat loss: 20 °C
No. of heaters: 3

$$Q_{\text{water}} = \frac{50}{\frac{20}{10} \times 42} \times 3600$$

$$Q_{\text{water}} = 714 \text{ l/h}$$

Refer to the documentation included with the valves for how to set the flow rate.



The pipe circuit must be made according to current regulations and by authorised personnel.

3.4 Regulation and frost protection

Regulation of the heating capacity is done by changing the fan speed. See section “3.5 Electrical connections”.

In addition, the water flow in the heating coil should be constant to allow for regulation of the heat supply through changing of the water temperature.

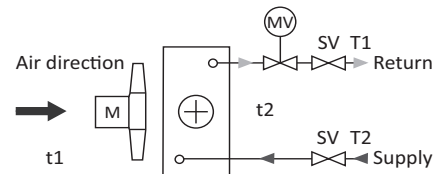

- M = Motor
- MV = Dynamic flow valve
- SV = Shut-off valve
- t1 = Inlet air temperature
- t2 = Outlet air temperature
- T1 = Return water temperature
- T2 = Supply water temperature

Figure 12. Constant flow in coil

Fans with fresh air supply must be protected against frost. When using water as heating medium an automatic control system with a frost indicator should be installed. The preferred method is with a stem bulb sensor in the return water. At low temperatures this stops the fan, closes the damper against the outside air and ensures full flow in the automatic regulator valve.

3.5 Electrical connections



The electrical connections must be made according to current regulations and by authorised personnel.

Connect the motors to the electrical supply.

The fans can be connected to different types of speed regulators. See the wiring diagrams on pages 10 to 13.

After connecting the motor, check the direction of rotation from the fan inlet side.

Directions of rotation

- VM-4 and -5: Counter-clockwise
- VM-6, -7 and -8: Clockwise

Access to the fan motor on units with mixing housings is typically done by removing a side plate opposite the damper shaft.

The damper motor has a terminal box for direct cable connection.

4. Maintenance

The air heaters are designed to give long and reliable operation and to require little service.



The electric system must be switched off and locked to avoid unintentionally starts when the air heaters are undergoing maintenance.

The air heaters must be kept clean at all times for optimum performance and best level of comfort. Inspect and clean the units as needed. Units installed in dust-filled environments require more frequent maintenance.

Refer to figure 1. Basic unit in the following sections.

4.1 Inspection

Air heaters without accessories on the inlet side can be checked directly.

Inspection of the inlet on units with mixing housings is typically done by removing a vertical side plate of the mixing housing opposite to the damper shaft.

4.2 Cleaning

Dust builds up inside the unit cabinets and reduce the performance if not removed.

Build-ups on fan suspensions, wire guards, heating coils and dampers can usually be removed by vacuum cleaning. Cleaning the inlet of the heating coil can be done after removing the fan unit with suspension. See section "4.4 Motor".

On the outlet side it is possible to remove the front grille.

Wall grilles for fresh air and wire guards for return air ducts must also be kept free from dust and foreign particles.

4.3 Impeller

Prior to delivery, the fan unit has been carefully balanced. If vibrations occur during operation, it is normally due to dust on the fan blades. If vibrations persist after cleaning; stop the unit and call for skilled assistance. Continued operation may damage the motor bearings.

4.4 Motor

The motor and impeller is a one piece assembly. The motor bearings are greased for life, i.e. approx. 30.000 working hours and cannot be greased anew. When the service life of the bearings has run out, they should be replaced. Replacement of the bearings should be carried out by a specialist. During replacement, remove the entire unit comprising fan suspension and fan. Afterwards, remove the suspension from the fan. When re-mounting, the fan must be centred carefully with equal blade clearance around the circumference.

4.5 Heating coil

The heating coil has copper tubes with aluminium fins and is sensitive to frost. If there is a risk of hard frost, it might be necessary – besides the established frost protection at the fresh air inlet – to empty the heating coil of water. In exposed installations it is recommended to supply the plant with antifreeze.

4.6 Damper

The damper function should be checked on occasion.

4.7 Filters

Filters from Novenco are made of synthetic material and must be cleaned occasionally to maintain fan performance. Cleaning is done either by vacuum cleaning the dirty side of the filter mat, rinsing from the clean side or by washing in lukewarm soap water at max. 40 °C. The filter mat can be washed four times, before it must be replaced.

During cleaning or replacement of the filter, draw out the filter cassette and insert a new filter after cleaning the mat retainers. The filter cassette is fitted with a handle. The retainers are of Velcro and reusable.

When ordering a new filter mat, observe the type and size of fan, e.g. VMA-62.

The filter condition must be checked 2 weeks after start-up of the fan and then once every month.

Recommended rise in differential pressure above the filter mat is 100 Pa.

4.8 Other components

Components for regulation, ventilation, water outlet and other accessories essential for the correct operation of the fan, need regular inspection and maintenance according to the manufacturer's instructions.

5. Electrical connection



The installation and connection to the supply network must be done by authorised personnel and according to current legislation, e.g. the EU standard for electromagnetic compatibility (EMC).

5.1 Motors

All motors are 1x230 V.

Sizes	Frequency [Hz]	RPMS	Power [W]	Current [A]
4-	50 /	1350 /	110 /	0.52 /
	60	1490	148	0.66
5-	50 / -	1300 / -	190 / -	0.66 / -
		1320 /	410 /	1.90 /
6-	50 /	1450	570	2.50
		60	910 /	390 /
7-	60	980	580	2.60
		920 /	470 /	2.30 /
8-		1080	730	3.20

Sizes	Starting current [A]	Ambient temp. ranges [°C]	Weight [kg]	Encapsulation
4-	1.20 / 1.18	-20 to 45	3.5	IP44
5-	-	-	-	
6-	4.40 / -	-15 to 60	9.2	IP54
7-	-	-	-	
8-	5.50 / -	-15 to 45	12.8	

Table 5. Motor specifications ¹

1.The motors comply with EU's ErP 2015 directive.

5.2 Regulators

When in operation, the 2.5 A and 5 A stepless TRIAC regulators generate audible noise.

Types	Regulation type	Voltage [V]	Max. current [A]	Encapsulation
RDG100T	Thermo-stat	1x230	4	IP30
NV515			6	IP34
5-step	Speed	1x230	1.5	IP54
			3.5	
			5	
			10	
Stepless			2.5	
			5	

Types	Max. current [A]	h [mm]	w [mm]	d [mm]	Weight [kg]
RDG100T	4	128	93	30.8	0.3
NV515	6	-	-	-	-

Table 6. Regulator specifications

Types	Max. current [A]	h [mm]	w [mm]	d [mm]	Weight [kg]
5-step	1.5	205	115	100	2.1
	3.5	255	170	140	5.0
	5	255	170	140	5.4
	10	325	300	185	13.2
Stepless	2.5	82	82	65	0.24
	5	160	83	81	0.59

Table 6. Regulator specifications

	Types				
	Ampere [A]	RDG100T [max. 4 A]	NV515 [max. 5 A]	5-step 1.5 A	5-step 3.5 A
4-	0.52 / 0.66	7 / 5	9 / 7	2 / 2	4 / 3
5-	0.66 / -	6 / -	7 / -	2 / -	3 / -
6-	1.90 / 2.50	2 / 1	2 / 2	- / -	1 / 1
7-	1.80 / 2.60	2 / 1	2 / 1	- / -	1 / -
8-	2.30 / 3.20	1 / 1	2 / 1	- / -	1 / -

	Types				
	Ampere [A]	5-step 5 A	5-step 10 A ¹	Stepless 2.5 A	Stepless 5 A
4-	0.52 / 0.66	9 / 7	15 / 13	4 / 3	9 / 7
5-	0.66 / -	7 / -	15 / -	3 / -	7 / -
6-	1.90 / 2.50	2 / 2	4 / 3	1 / 1	2 / 2
7-	1.80 / 2.60	2 / 1	4 / 3	1 / -	2 / 1
8-	2.30 / 3.20	2 / 1	4 / 3	1 / -	2 / 1

Table 7. Max. number of motors per regulator at 50 / 60 Hz

1.The regulator cannot be used with the RDG100T.

5.3 Re-configuration of NV515 – 5-step

The NV515 – 5-step regulators offer alternative configuration options for enabling of minimum speed and triggering of external devices.

Re-configuration of fan speeds to knob positions

The minimum fan speed is per default unassigned. Follow the procedure below to re-configure the knob positions.

1. Disconnect power for the regulator.
2. Remove the front cover.
3. Re-connect the coloured fan speed control wires. See appendix "E. NV515 – 5-step regulators" on page 12.



The fan speed control wires must only be moved between the seven regulated output voltage positions. It is recommended to keep the colour order of the wires and to leave the blue wire at 0 V, which is Off for knob position 0.

4. Remount the front cover.
5. Connect power to the regulator.

Connection of external device for knob position 0

The NV515 – 5-step regulator has an unregulated output on the connectors N1 and L1. These are active for knob position 0 and can be used to trigger an LED, a valve, a motor etc. See figures 17 and 18 (right) on page 12.

1. Disconnect power for the regulator.
2. Remove the front cover.
3. Connect external device to the connectors N1 and L1.
4. Remount the front cover.
5. Reconnect power for regulator.

5.4 Wiring diagrams

The fan motors are connected through a voltage regulator. See the appendices for wiring diagrams of how to connect the thermostats and how to connect the thermostats with the regulators.

Several fan motors can be connected in parallel to the same regulator. See table 7. "Max. number of motors per regulator at 50 / 60 Hz".

6. Troubleshooting

In case of breakdowns, the following checklists should be completed, before calling for service.

Lacking performance

- Damper closed
- Ducts clogged
- Supply fan stopped
- Motor defective
- Motor disconnected
- Wrong direction of rotation

Noise and vibrations

- Motor bearings defective
- Impeller out of balance
- Impeller worn or damaged
- Bolts or components loose

Fans operating in the stalling area, may result in breakdowns.

7. Inspection and test

It is recommended to test and inspect the air heaters and installation at regular intervals with regard to operability and operating conditions.

Extent of inspection

- Measure power consumption
- Check torques for fixing bolts and correct if necessary
- Cleaning
- Visual inspection of cabinet, pipe and electric connections

Enter all values and observations in a log.

8. Sound

Sizes	RPMs	Sound power Level total [dB]	Sound pressure level [dB(A)] ¹
4-	1350	59	45
5-	1300	–	–
6-	1400	74	60
7-	910	71	57
8-	950	76	62

Table 8. Sound data, VMA and VMB without accessories

1.Sound pressure level at a distance of 5 m, room of 1.500 m³, normal reflection, direction factor Q = 2

9. Safety

The air heaters must be installed according to Novenco', the current and the local safety regulations. At a minimum these include EN 13850. It is recommended to review and revise safety procedures regularly.

Safety check

- Test if safety procedures and the installation work correctly.
- Check if safety regulations have been changed and if the

installation needs revising.

- Consider taking additional measures to improve the safety of the installation.

10. Disposal

Dispose of air heaters suitable for scrapping in environmentally safe ways and in accordance to current regulations.

The air heaters and especially the electric motors contain recyclable materials. Make sure worn-out motors and fan parts are disassembled and recycled for the benefit of the environment

11. Patents and trademarks

Novenco[®], ZerAx[®], 诺文科, 诺万科 and 诺克 are registered trademarks of Novenco Marine & Offshore A/S. ZerAx[®] is a registered trademark of Novenco Building & Industry A/S. AirBox[™], NoVa[™] and NovAx[™] are trademarks of Novenco Building & Industry A/S.

Other trademarks that appear in this document are the property of their respective owners.

Copyright (c) 2003 - 2023, Novenco Building & Industry A/S. All rights are reserved.

12. Quality management

Novenco is ISO 9001 certified. This means that all air heaters are inspected and tested, before leaving the production.

13. Warranty

Novenco provides according to law a standard 12 months warranty from the product is sent from the factory. The warranty covers materials and manufacturing defects. Wear parts are not covered. Extended warranty can be agreed upon.

14. Spare parts

Contact Novenco for information about and ordering of spare parts.

15. Product lifetime

The air heaters have a product lifetime of 20 years. Storage, installation and maintenance must be in accordance with Novenco's instructions, which include this installation and maintenance guide.

16. Declaration of conformity

The Machinery Directive 2006/42/EU, part 2, A.

Novenco Building & Industry A/S
Industrivej 22
4700 Naestved
Denmark

hereby declares that the air heaters type VMA and VMB have been manufactured in accordance to and comply with the European Council's directives 2006/42/EU regarding mutual approximation of the machinery laws (the Machinery Directive) of the member states.

EU directives

- ECO design 2009/125/EU and energy labelling regulation 2017/1369/EU
- EMC 2014/30/EU
- LVD 2014/35/EU
- Machinery 2006/42/EU

UK regulations

- Ecodesign for ErP 2010 and
- Energy Information 2011
- Electrical Equipment (Safety) 2016
- EMC 2016
- Supply of Machinery (Safety) 2008

Applied standards and regulations

EU 327/2011:

Fans driven by motors with electric power between 125 W and 500 kW

EN ISO 12100:2010

Safety of machinery

- General principles for design
- Risk assessment and risk reduction

EN ISO 13857:2019

Safety of machinery - Safety distances

EN 60204-1:2018

Safety of machinery - Electrical equipment of machines Part 1: General Requirements

EN 61000-6-2:2019

EMC - Part 6-2: Generic standards - Immunity for industrial environments

EN 61000-6-3:2007 + A1:2011

EMC - Part 6-3: Generic standards - Emission standard for residential,

commercial and light-industrial environments

EN 61800-3:2018, class C2

Adjustable speed electrical power drive systems, EMC requirements and specific test methods

It is conditioned for the validity of the warranty that Novenco' instructions for installation and maintenance have been followed.

UK representative

Novenco Building & Industry UK Ltd
2A Halifax Road
Bowerhill
Wiltshire
SN12 6YY
United Kingdom

Phone: +44 800 681 60 09

E-mail:

info-uk@novenco-building.com

Naestved, 03.04.2023

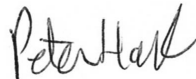

Peter Holt

Technical director

Novenco Building & Industry A/S



Appendices – wiring diagrams

A. Thermostats RDG100T and NV515

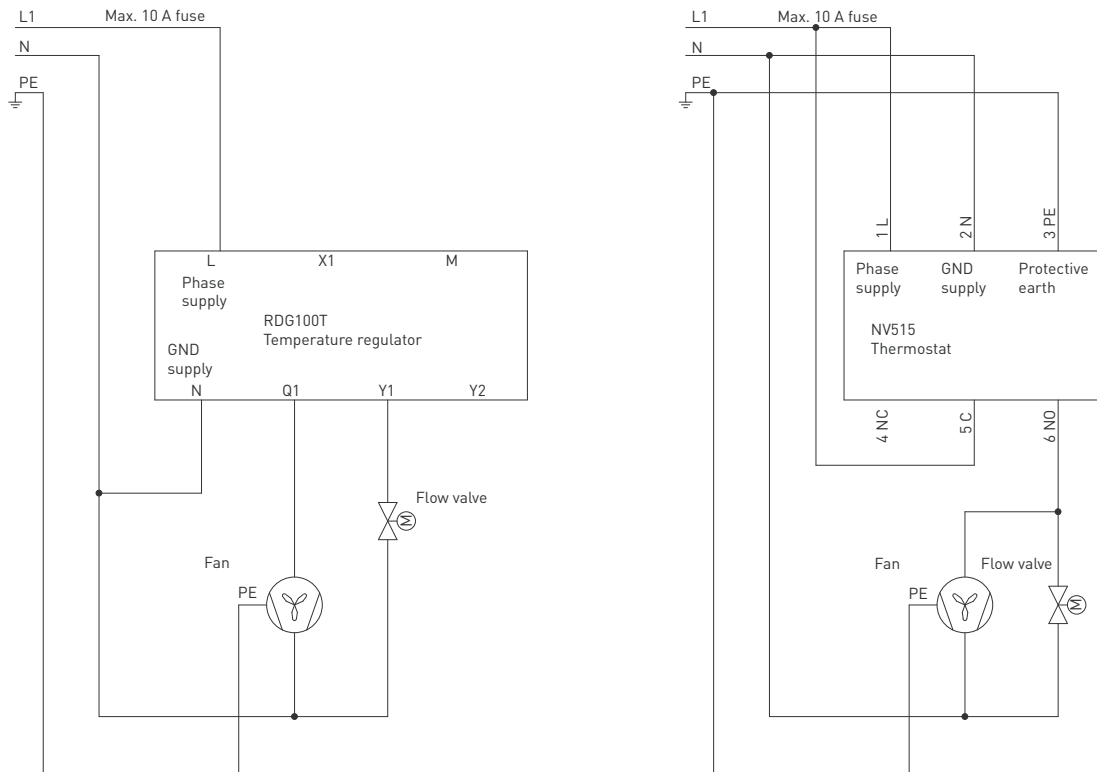

Figure 13. Wiring diagrams for RDG100T and NV515 thermostats

B. RDG100T – 5-step regulators

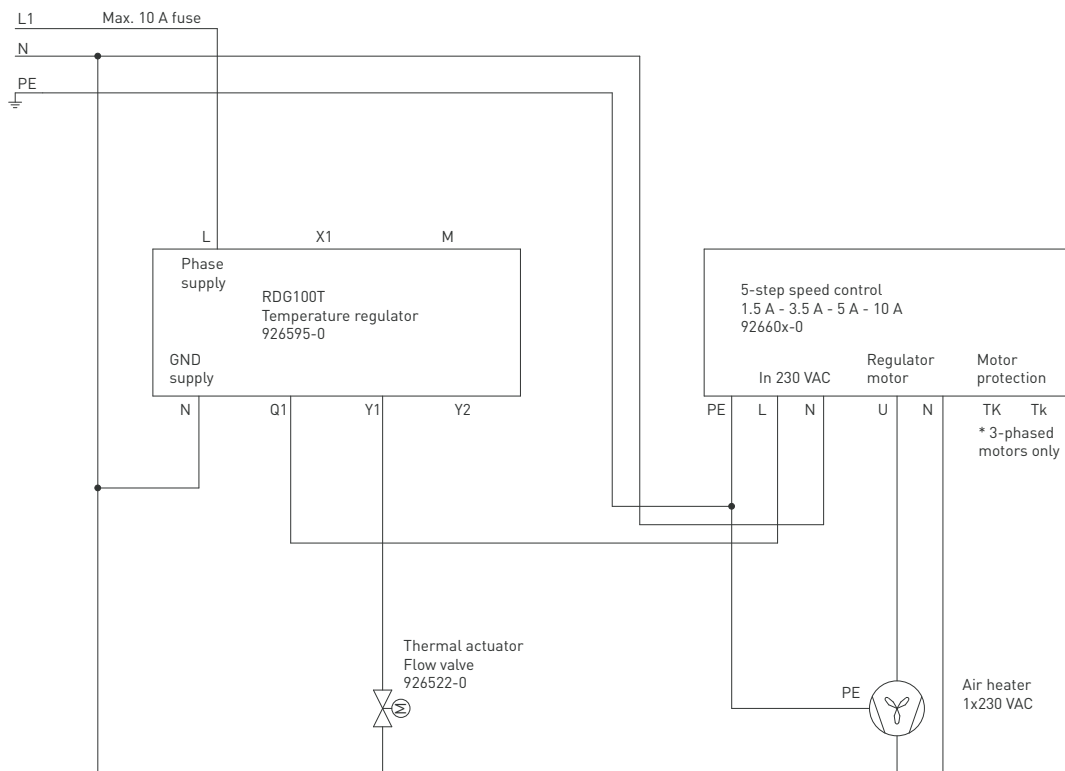

Figure 14. Wiring diagram for RDG100T and 5-step regulators 1.5 A, 3.5 A, 5 A and 10 A

C. RDG100T – stepless regulator 2.5 A

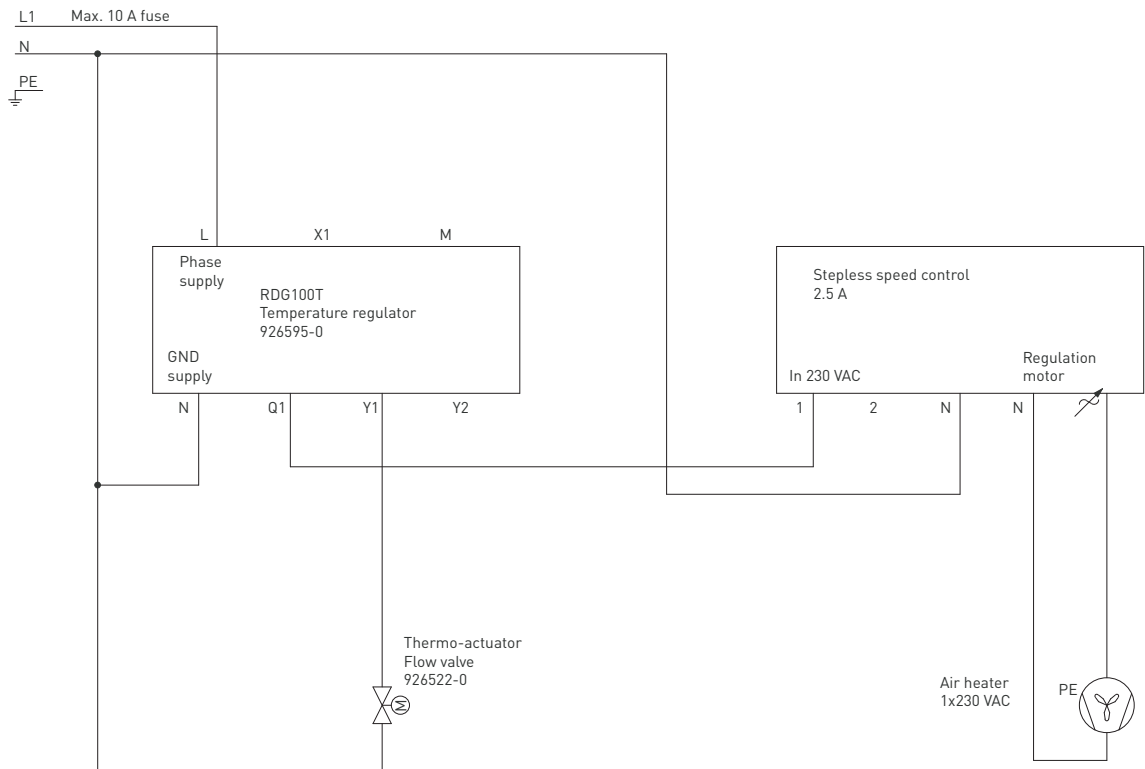

Figure 15. Wiring diagram for RDG100T and stepless regulator 2.5 A

D. RDG100T – stepless regulator 5 A

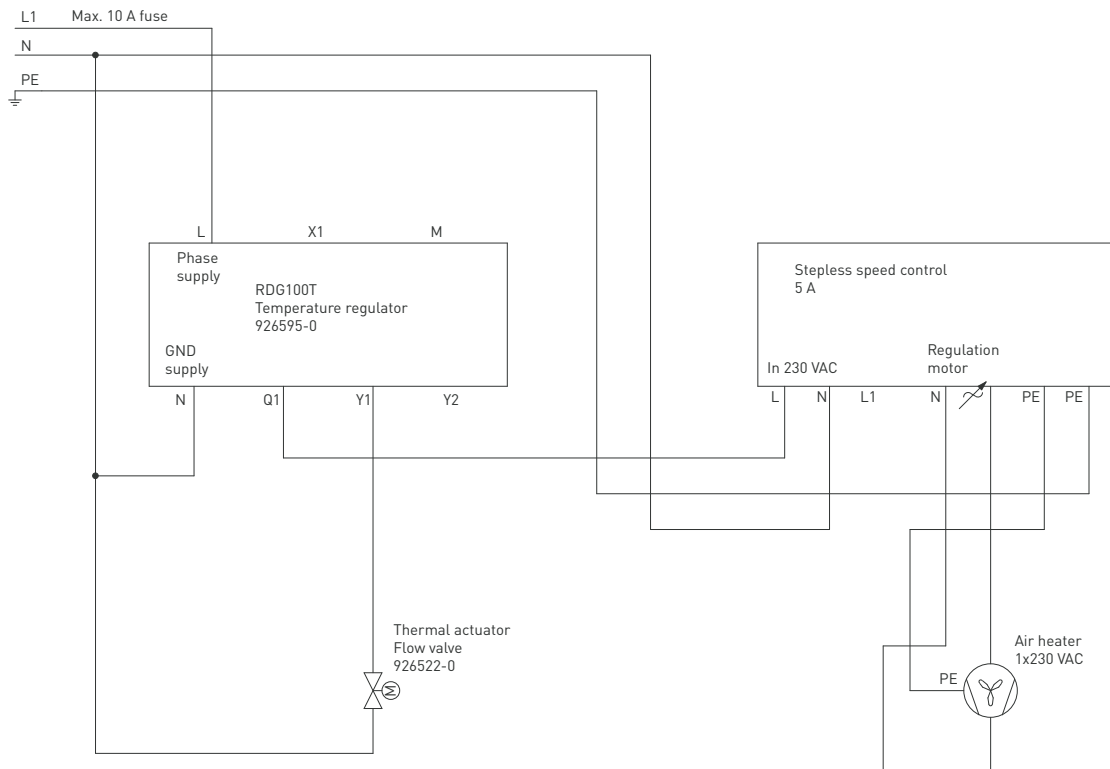

Figure 16. Wiring diagram for RDG100T and stepless regulator 5 A

E. NV515 – 5-step regulators

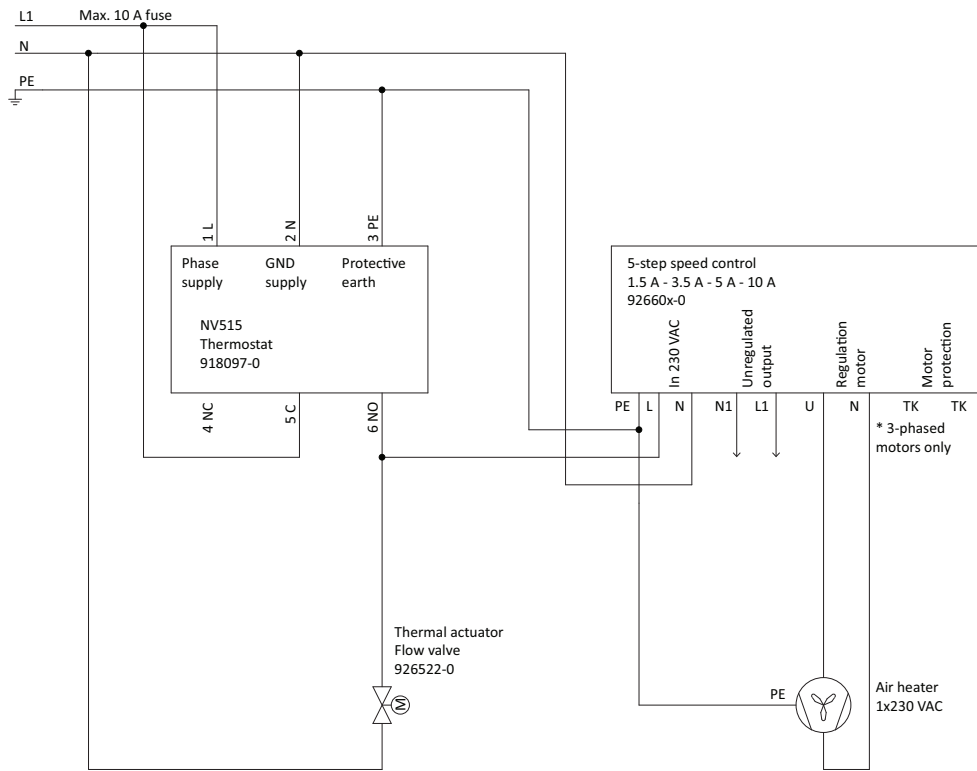

Figure 17. Wiring diagram for NV515 and 5-step regulators 1.5 A, 3.5 A, 5 A and 10 A

Default		Re-connect example		Regulated output voltages [VAC]	Fan speeds associated with output voltages
Knob positions	Coloured wires	Knob positions	Coloured wires		
0	Blue	0	Blue	0	Off
---	---	1	Grey	80	Minimum
1	Grey	2	Purple	110	Slow
2	Purple	3	Orange	140	Medium
3	Orange	4	Brown	170	Moderate
4	Brown	---	---	190	Fast
5	Red	5	Red	230	Maximum

Table 9. Default and re-connect settings for NV515 – 5-step regulators



Figure 18. NV515 – 5-step regulator, minimum fan speed enabled (left) and location of N1 and L1 connectors (right)

F. NV515 – stepless regulator 2.5 A

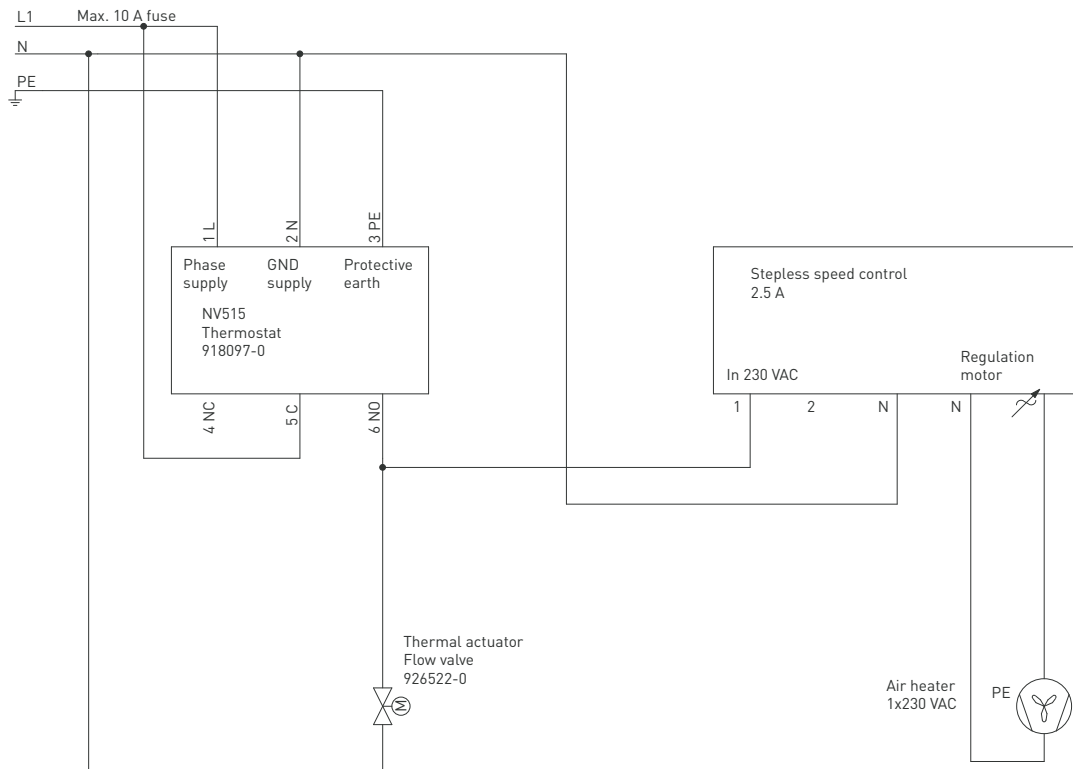

Figure 19. Wiring diagram for NV515 and stepless regulator 2.5 A

G. NV515 – stepless regulator 5 A

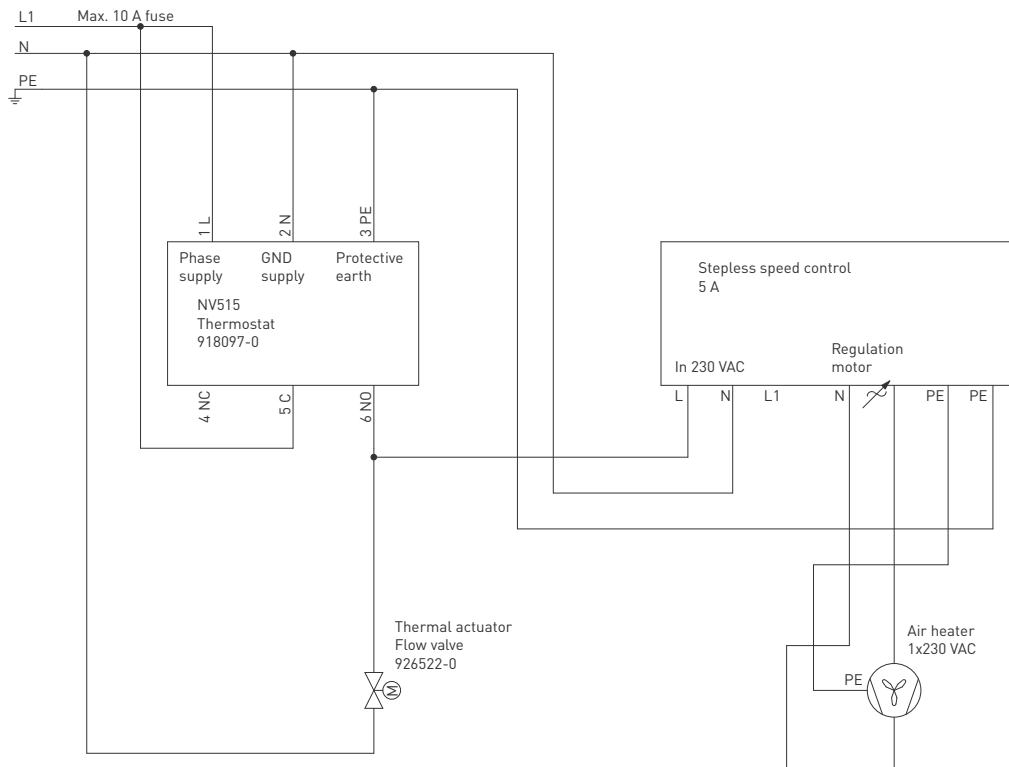

Figure 20. Wiring diagram for NV515 and stepless regulator 5 A

Pure competence in air.

Building & Industry

NOVENCO 

SCHAKO Group

WWW.NOVENCO-BUILDING.COM