

Pure competence in air.

NOVENCO® CENTRIFUGAL FANS

CND-CNF

STANDARD, ATEX AND EX

Building & Industry



SCHAKO Group



PRODUCT FACTS

PRODUCT

The Novenco® centrifugal fans type CND and CNF are light, compact low-pressure and medium fans with high efficiency, low sound levels and good operating economy, designed for universal installation.

APPLICATION

The CND and CNF are, due to the choice of material and finishing, well suited for ventilation in aggressive environments. CNF versions for installation in ATEX and EX zones are also available.

RANGES

The CNF fans are made for 10 to 25% higher RPMs than the CND, depending on fan size. The CNF impellers are all-welded, compared to the lighter spot welded impeller of the CND.

CONSTRUCTION

Fan casings have rectangular side plates for universal installation. The CND and CNF are available in directly coupled and belt-driven versions.

The impeller has backward-curved blades.

FAN SPECIFICATIONS

All values are at 20 °C.

Casing thicknesses: 3 mm side plates and 2 mm scrolls

Impeller diameters: Ø315 to Ø710 mm for both CND and CNF fans

Airflow rates: • CND: 0.2 to 10 m³/s

• CNF: 0.2 to 11 m³/s

Pressure increases: • CND: Up to 2000 Pa

• CNF: Up to 4000 Pa

Motor efficiencies: Between 84 and 93%

Total efficiencies: Up to 84% depending on fan size

MOTORS

Asynchronous motors are standard.

Belt-driven: Structural shape B3 (base motor)

Directly coupled: Structural shape B5 (large flange)

Dimension standard: IEC-72

Efficiency classes: IE1- IE3

Electrical standard: IEC-34

Insulation: Class F

MOTOR INSTALLATION SIZES

Impeller diameters [mm]	Motor sizes
315	80- 112
400	80- 132
450	80- 132
500	80- 132
560	100- 160
630	100- 160
710	112- 180

Directly coupled fans

Impeller diameters [mm]	Motor sizes
315	80- 132
400	80- 132
450	80- 160
500	80- 160
560	100- 160
630	100- 180
710	112- 200

Belt-driven fans

MATERIALS

Casing: Hot-rolled sheet steel, Domex 240, hot-dip galvanised or stainless steel

Impeller: Domex 500, hot-dip galvanised or stainless steel

CLASSIFICATIONS

ATEX and marine EX: CNF ATEX versions meet directive 2014/34/EU for category 2G/D; CNF EX versions meet guideline IACS F29/2005

Corrosion categories: C3 as standard and C5-I (very high) as option. Categories are in accordance to DS/EN ISO 12944-2.

Flange standard: Eurovent 1/2 for inlet

Sound: ANSI/AMCA 300-14

Technical capacities: DS/ISO 21940-11:2016; DS/ISO 21940-14:2012; EN ISO 5801:2017

Temperature range, standard:

-20 to +70 °C

ACCESSORIES

Installation

- Anti-vibration mountings
- Base plate
- Counter flanges
- Duct spigots
- Flexible connections

Protection

- Brass or copper inlet cones
- Wire guards for inlet and outlet

Service

- Drain
- Inspection door



CND-CNF with inlet cone of brass (accessory)

DESCRIPTION

The centrifugal fans type CND and CNF are light, compact low-pressure and medium fans designed for universal installation in compost plants and greenhouses as well as light industrial plants in aggressive environments.

INSTALLATION SIZES

Type CND is produced in 7 sizes with impeller diameters from 315 to 710 mm, airflow rates from 0.2 to 10 m³/s and total pressures up to approximately 2000 Pa.

Type CNF is produced in 7 sizes with impeller diameters from 315 to 710 mm, airflow rates from 0.2 to 11 m³/s and total pressures up to approximately 4000 Pa.

CONSTRUCTION

Centrifugal fans type CND and CNF consist of the following main components.

Fan casing, constructed from two rectangular side plates and an all-welded scroll.

Inlet cone, mounted in the front side plate with a spigot for duct connection and designed to guide the air with as little loss as possible.

Impeller with 8 backward-curved blades designed and produced with the same geometry and material for both CND and CNF. However, where the CND is spot welded, the CNF is fully welded and thus designed for higher operating RPMs.

Bearing part with two dust-proof and waterproof deep groove ball bearings mounted in flanged bearing casings. The bearings have lifetime lubrication.

SURFACE TREATMENT

All the fan parts are protected and treated with min. 60 µm hot-dip galvanisation.

MOTORS

These are in accordance with customer specifications. Directly coupled motors have B5 flanges, i.e. large flanges for all motor sizes. Belt-driven motors have B3 base flanges.

ENVIRONMENTS

All CND and CNF fans are designed for the temperature range -20 to +70 °C.

The choice of materials and finishing is in accordance to DS/EN ISO 12944-2, which as standard covers corrosion category C3 (middle) and optionally C5-I (very high). The C5-I variants offer lifetimes of 8-10 years with hot-dip galvanisation and a coating thickness of 60- 80 µm.

ACCESSORIES

Duct spigot - inlet, loose duct spigots are available for connection of ducts with flexible connections.

Flexible connections are available for both circular (inlet) and rectangular (outlet) connectors.

Counter flanges are for installation on fan outlets, consist of welded steel frames and are finished with min. 60 µm hot-dip galvanisation.

Inspection doors, CND and CNF fans are available with inspection doors located in the scroll casing. The inspection doors are available in two sizes, depending on the fan size. Please state the location of the door in relation to the outlet direction.

Drains allow condensed water to escape. Please state the location of the drain plug in the side plates of the fan casing the position is in relation to the outlet direction.

Wire guards for the inlet (circular) and outlet (rectangular) respectively.

Anti-vibration mountings, the location and choice of anti-vibration mountings are shown in the installation instructions. They are available for both the CND and the CNF.

Brass or copper inlet cones are available in brass or copper for both CND and CNF fans for use in environments with increased safety.

CLASSIFICATIONS

The CND and CNF fans meet the requirements for operation in corrosion category C3 as standard and optionally in category C5-I.

The entire range of CNF fans is also

available in ATEX or EX versions. The ATEX versions comply with the ATEX directive 2014/34/EU for category 2 G/D fans.

The EX versions are for marine use and have inlet cones of brass in accordance to guideline IACS F29/2005 for non-sparking fans.

AIRBOX CALCULATION PROGRAM

The AirBox program is Novenco's calculation and configuration tool for fans. Input to the program are the requirements for airflow and pressure as well as specific characteristics of the operating environment. Further requirements for the fan, motor and accessories are also input and form the basis for calculation of possible solutions.

Novenco AirBox is available on www.novenco-building.com in the Support > Software section. It requires registration, checks automatically for updates and is for free.



PERFORMANCE CURVES

CND 315 ¹

Max. = 4618 RPM
 l_{pt} = 0.0951 kg x m²

CNF 315 ²

Max. = 5874 RPM
 l_{pt} = 0.0951 kg x m²
 δ = 1.20 kg/m³ (at 20° C)

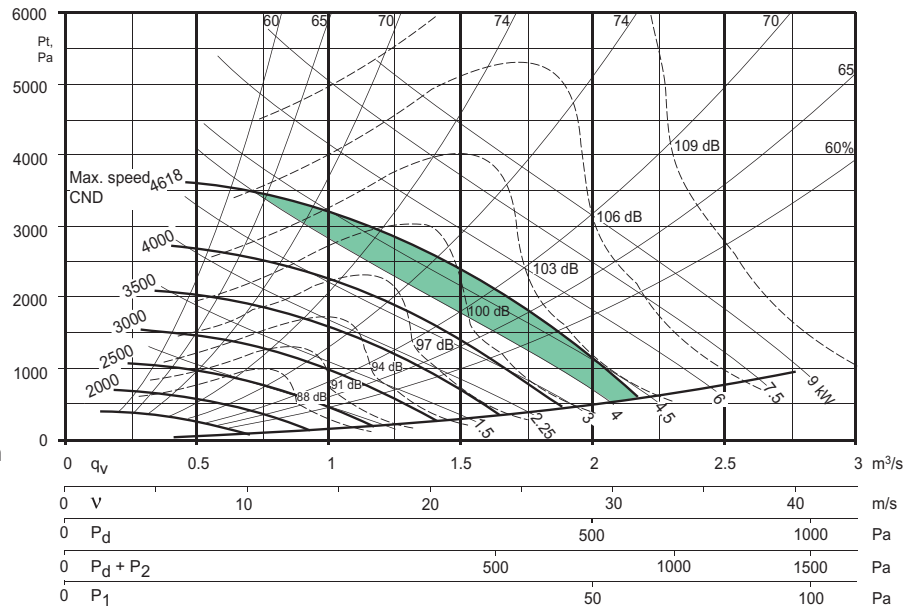

1. The shaded area for CND fans represents a work area where it is questionable if suitable motors are available.

2. Motors for CNF fans in the work area above the max. speed of the CND are unavailable.

BASIS FOR CHART

(Arr. D)

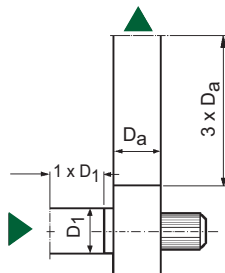

SYMBOLS

p_t	= total pressure	q_v	= volume flow
p_d	= dynamic pressure, outlet	n	= RPM
p_1	= connection loss, inlet	η	= efficiency in %
p_2	= connection loss, outlet	kW	= power demand, impeller
v	= air speed, outlet	dB	= sound power level, outlet

CND 400

Max. = 3426 RPM
 I_{pt} = 0.2440 kg x m²

CNF 400¹

Max. = 4090 RPM
 I_{pt} = 0.2440 kg x m²
 δ = 1.20 kg/m³ (at 20° C)

1. The shaded area for CNF fans represents a work area where it is questionable if suitable motors are available.

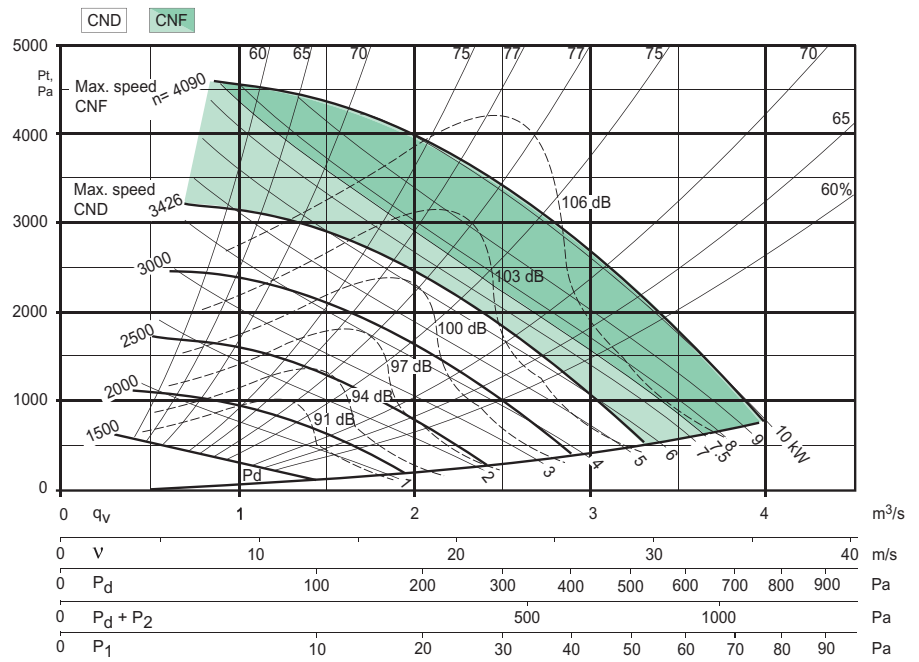

CND 450

Max. = 2957 RPM
 I_{pt} = 0.4218 kg x m²

CNF 450

Max. = 3365 RPM
 I_{pt} = 0.4218 kg x m²
 δ = 1.20 kg/m³ (at 20° C)

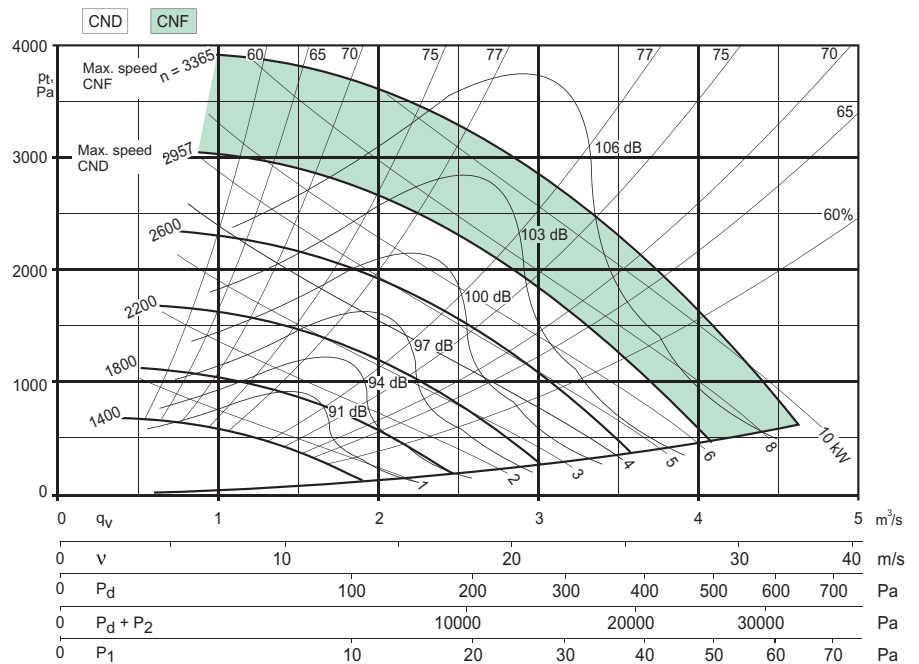

BASIS FOR CHART

(Arr. D)

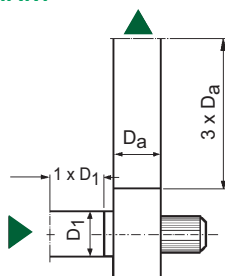

SYMBOLS

- | | | | |
|-------|----------------------------|--------|-----------------------------|
| p_t | = total pressure | q_v | = volume flow |
| p_d | = dynamic pressure, outlet | n | = RPM |
| p_1 | = connection loss, inlet | η | = efficiency in % |
| p_2 | = connection loss, outlet | kW | = power demand, impeller |
| v | = air speed, outlet | dB | = sound power level, outlet |

CND 500

Max. = 2592 RPM
 I_{pt} = 0.6430 kg x m²

CNF 500

Max. = 2927 RPM
 I_{pt} = 0.6430 kg x m²
 δ = 1.20 kg/m³ (at 20° C)

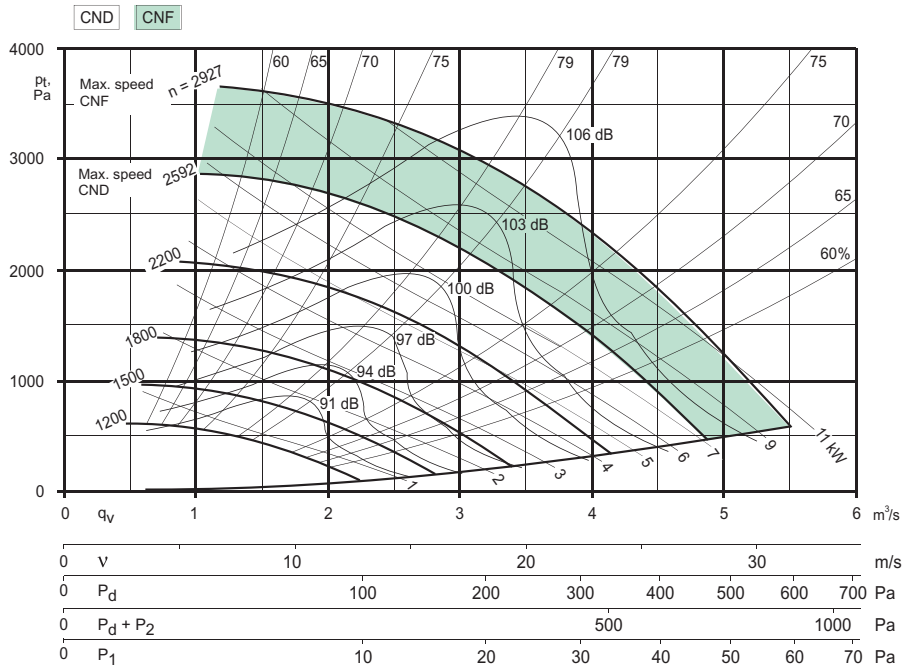

CND 560

Max. = 2249 RPM
 I_{pt} = 1.0212 kg x m²

CNF 560

Max. = 2464 RPM
 I_{pt} = 1.0212 kg x m²
 δ = 1.20 kg/m³ (at 20° C)

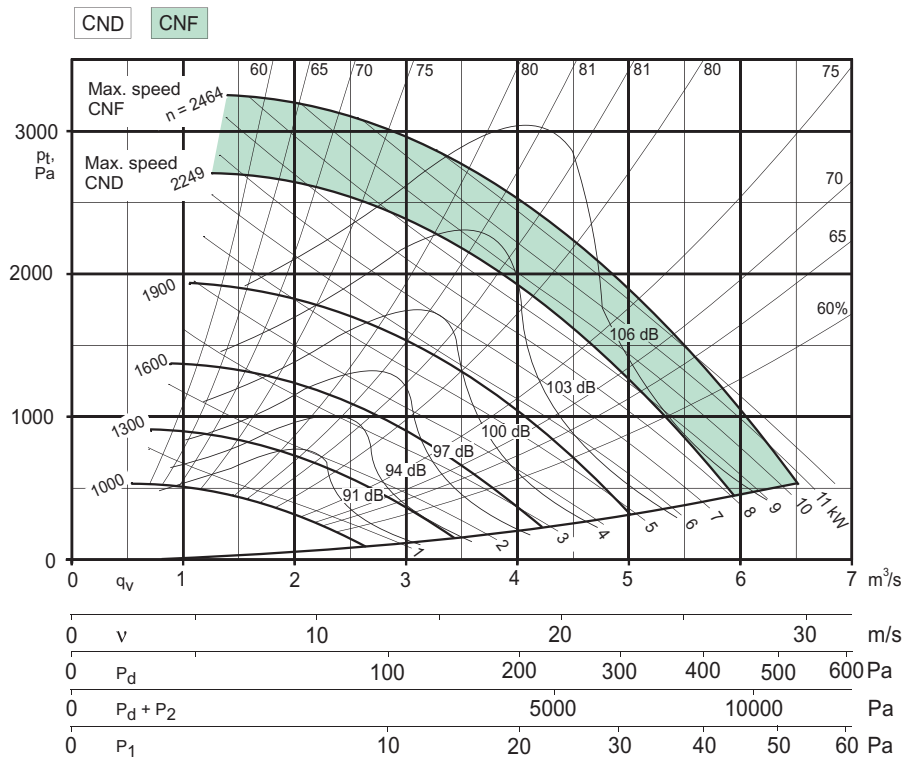

BASIS FOR CHART

(Arr. D)

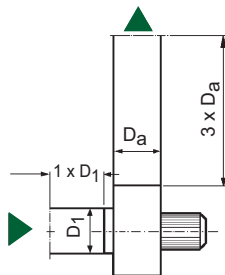

SYMBOLS

- | | | | |
|-------|----------------------------|--------|-----------------------------|
| p_t | = total pressure | q_v | = volume flow |
| p_d | = dynamic pressure, outlet | n | = RPM |
| p_1 | = connection loss, inlet | η | = efficiency in % |
| p_2 | = connection loss, outlet | kW | = power demand, impeller |
| v | = air speed, outlet | dB | = sound power level, outlet |

CND 630

Max. = 2086 RPM
 I_{pt} = 2.2571 kg x m²

CNF 630

Max. = 2387 RPM
 I_{pt} = 2.2571 kg x m²
 δ = 1.20 kg/m³ (at 20° C)

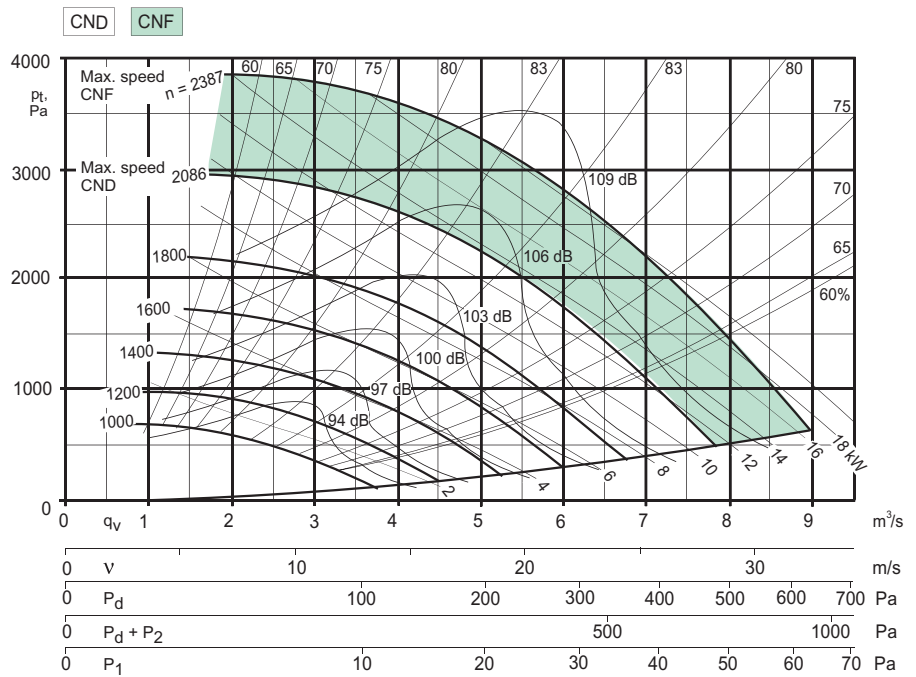

CND 710

Max. = 1797 RPM
 I_{pt} = 3.6479 kg x m²

CNF 710

Max. = 1994 RPM
 I_{pt} = 3.6479 kg x m²
 δ = 1.20 kg/m³ (at 20° C)

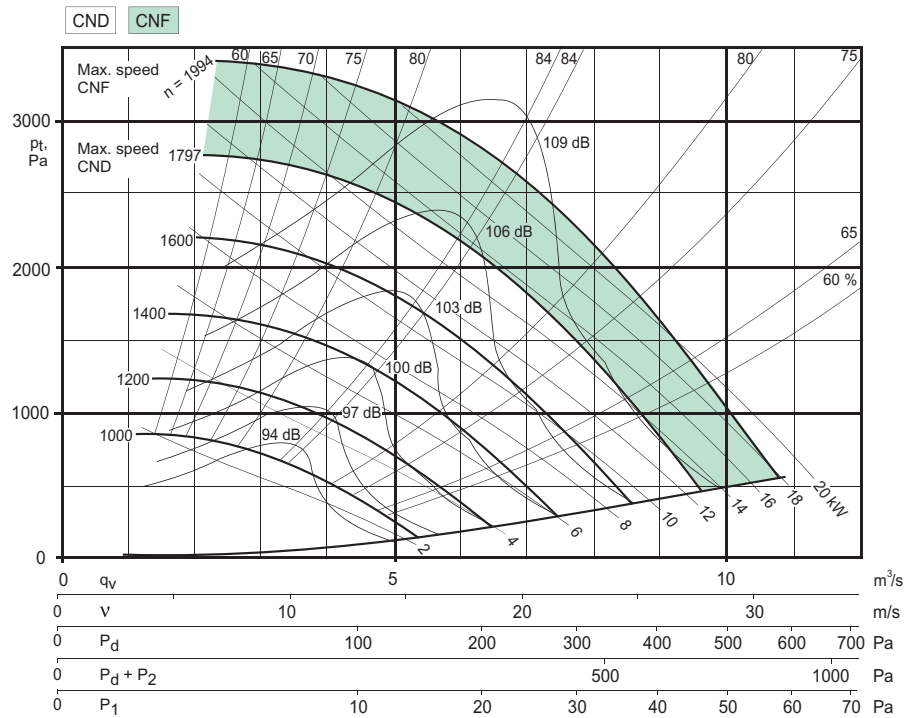

BASIS FOR CHART

(Arr. D)

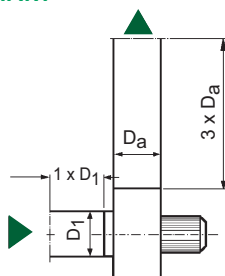

SYMBOLS

- | | | | |
|-------|----------------------------|--------|-----------------------------|
| p_t | = total pressure | q_v | = volume flow |
| p_d | = dynamic pressure, outlet | n | = RPM |
| p_1 | = connection loss, inlet | η | = efficiency in % |
| p_2 | = connection loss, outlet | kW | = power demand, impeller |
| v | = air speed, outlet | dB | = sound power level, outlet |

DIMENSIONS

CND AND CNF FANS

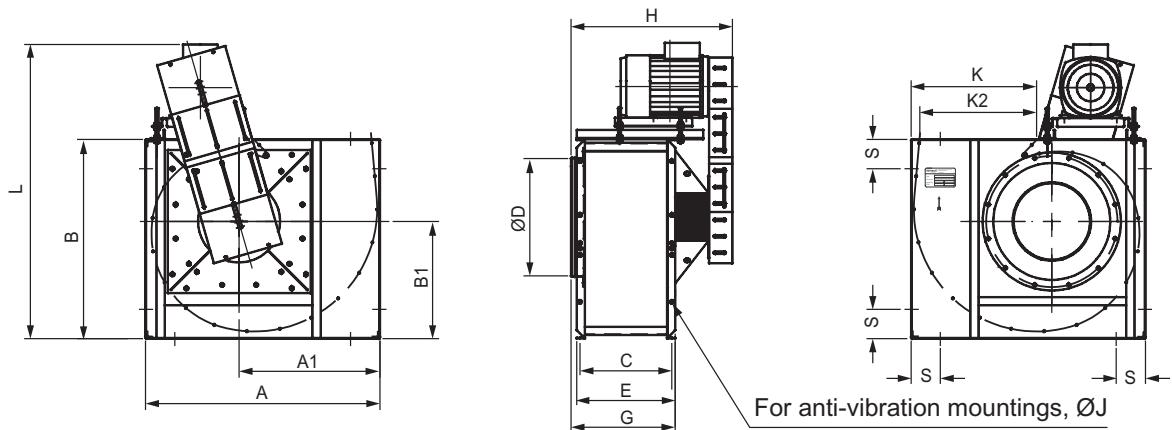

Belt-driven fans

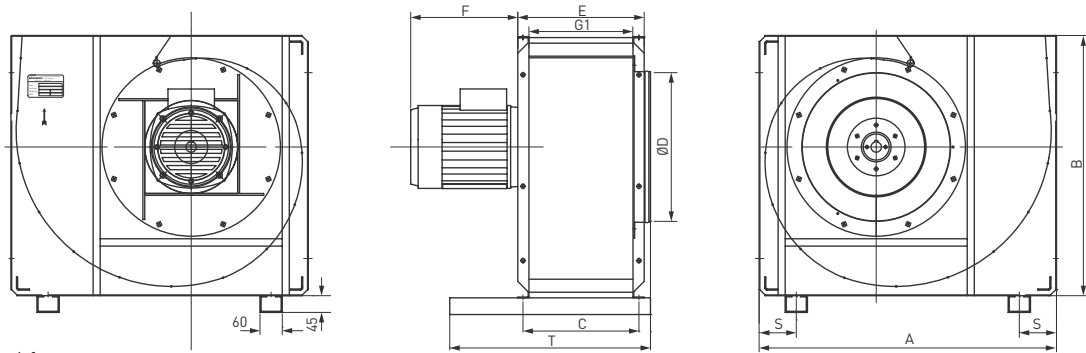

Directly coupled fans

Sizes	Dimensions [mm]															
	A	A1	B	B1	C	ØD = K2	E	F ¹	G	G1	H	ØJ	K	L	S	T
315	690	410	595	345	252	315	280	24	297	220	525	11.5	345	1040	100	475
400	800	485	700	400	312	400	340	24	357	280	585	11.5	430	1120	100	540
450	891	543	760	445	347	450	375	29 23.5	392	315	655	14	480	1175	125	610
500	1000	600	850	500	392	500	420	29 28.5	443	350	690	14	535	1255	125	670
560	1121	673	953	560	437	560	465	29 28	488	395	795	14	595	1440	125	780
630	1246	760	1063	622	482	630	510	26 24	533	440	840	14	665	1525	125	825
710	1405	869	1135	672	537	710	577	31	595	497	910	14	750	1620	125	940

1. This value must be subtracted from the motor length to obtain how much the motor protrudes outside of the fan casing. Refer to motor catalogue. In fields with two values the upper is for the belt-driven versions and the lower for the directly coupled.

FAN WEIGHTS WITHOUT MOTORS

Sizes	Directly coupled [kg]	Belt-driven [kg]
315	40	62
400	59	78
450	77	100
500	84	118
560	113	165
630	153	206
710	187	255

OUTLET FLANGES

Counter flanges with the same bolt holes as the outlet flanges are available as accessories.

Connection ducts are made with the same internal dimensions as the fan outlet opening (A x B).

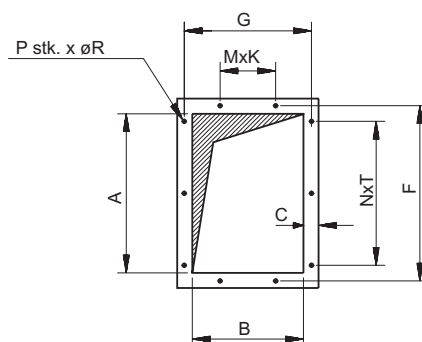

Sizes	Dimensions [mm]											
	A	B	C	F	G	K	M	N	T	P	R	
315	315	220	30	347	252	110	1	2	142.5	10	7	
400	400	280	30	432	312	140	1	2	185	10	7	
450	450	315	30	482	347	125	2	2	185	12	7	
500	500	350	35	536	386	125	2	3	155	14	7	
560	560	395	35	596	431	125	2	3	155	14	7	
630	630	440	35	666	476	170	2	3	200	14	7	
710	710	497	40	750	537	150	3	4	170	18	10	



POSITION DESIGNATIONS

RD 0

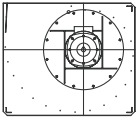

RD 90

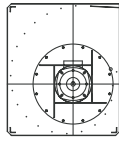

RD 180

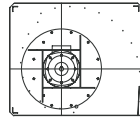

RD 270

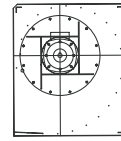

Directly coupled and low motor bracket for belt drive

LG 0

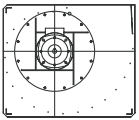

LG 90

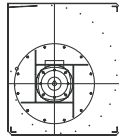

LG 180

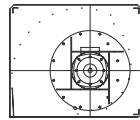

LG 270

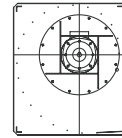

LG/1

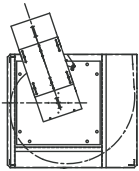

LG/2

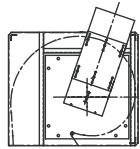

LG/3

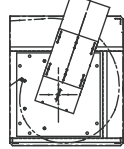

LG/4

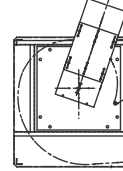

Belt-driven with motor mounted on fan casing. Refer to the AirBox software for full array of motor positions

RD/1

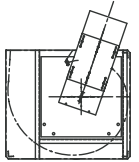

RD/2

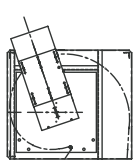

RD/3

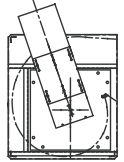

RD/4

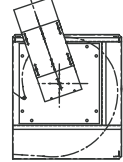

Positions are in accordance with Eurovent seen from motor side.

IMPELLER POSITIONS

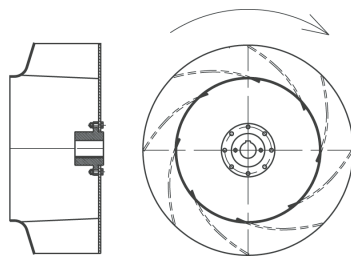

Pos. LG

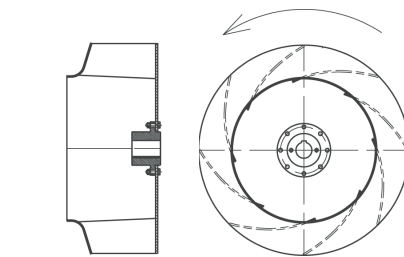

Pos. RD

MOTORS

MOTOR INSTALLATION SIZES AND WEIGHTS

The tables show the maximum motor sizes that can be installed on the fans. Directly coupled fans have flange mounted motors. Belt-driven fans have foot mounted motors.

The motor junction box must be coordinated with the fan motor cover.

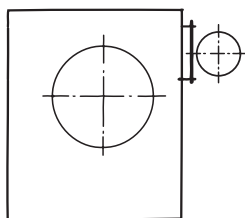

Motor on side
– vertical motor plate

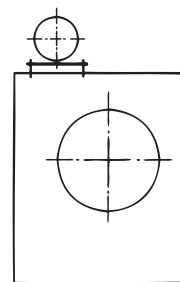

Motor on top
– horizontal motor plate

DIRECTLY COUPLED MOTORS

Fan sizes	Motor sizes
315	80-112
400	80-132
450	80-132
500	80-132
560	100-160
630	100-160
710	112-180

BELT-DRIVEN - MOTOR ON SIDE

Fan sizes	Max. motor	
	Motor sizes	Weight [kg]
315	112	40
400	112	40
450	112	40
500	132	70
560	132	70
630	132	70
710	132	70

BELT-DRIVEN - MOTOR ON TOP

Fan sizes	Max. motor	
	Motor sizes	Weight [kg]
315	112	40
400	112	40
450	112	40
500	132	70
560	132	70
630	132	70
710	132	70

MAX. RPM FOR CND/CNF

Fan types CND and CNF are designed and produced with the same geometry. The impeller in the CND is spot welded and the CNF is fully welded and thus designed for higher operating RPMs.

Steel quality: Domex 500

Surface treatment: Hot-dip galvanisation, approximately 60 µm zinc

Sizes	Max. RPMs	
	CND	CNF
315	4618	5874
400	3426	4090
450	2957	3365
500	2592	2927
560	2249	2464
630	2086	2387
710	1797	1994

LOW-MOUNTED MOTOR BRACKET FOR LARGE MOTORS

Large motors are mounted on low motor brackets bolted to the fan casing. The low centre of gravity and the large distances between the installation points stabilise the installation.

Required motor position and fan position

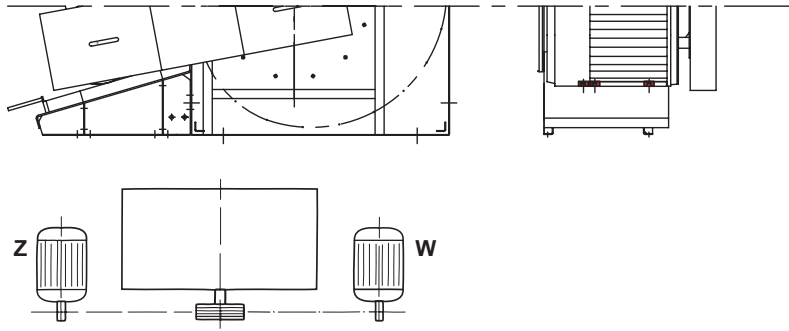

SHAFT END OF BELT-DRIVEN FANS

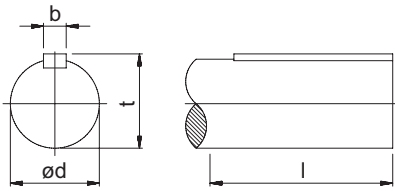

Fan sizes	Dimensions [mm]			
	d	l	b	t
315	28h6	30	8	31
400	28h6	30	8	31
450	38h6	50	10	41
500	38h6	50	10	41
560	48h6	70	14	51
630	48h6	70	14	51
710	65h6	70	18	69



ACCESSORIES

DUST SPIGOTS

The spigots are available as loose supplies and used for connection of ducts with flexible connections. They are standard on both CND and CNF.

Material: Steel

Surface treatment: Hot-dip galvanised, approx. 60 µm



Duct spigots

FLEXIBLE CONNECTIONS

The connections are available for duct spigots and outlet flanges.

Versions in different materials are available for both flame-proof flexible connections and incombustible flexible connections.

Material quality: Perl E 6

Temperature range: -30 to +80 °C

Material quality: Alpha Maritex

Temperature range: -36 to +260 °C

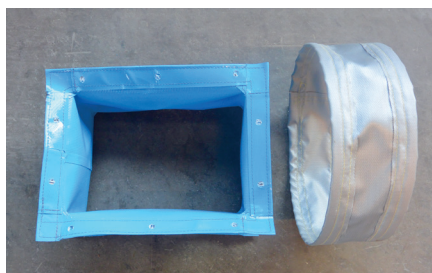

Flexible connections

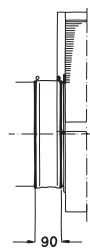

Inlet

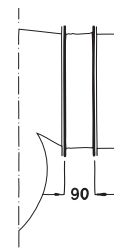

Outlet

COUNTER FLANGES

The flanges are for installation on the fan outlets. The constructions are welded steel frames.

Material: Steel Domex 240

Surface treatment: Hot-dip galvanised, approx. 60 µm

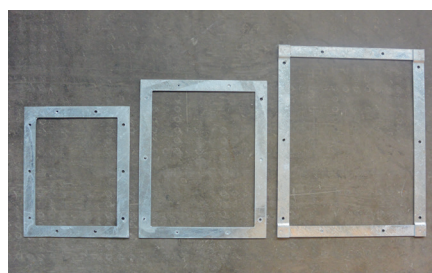

Counter flanges

WIRE GUARDS

The nets are for the inlet (circular) and outlet (square) respectively.

Material: Steel wire

Surface treatment: Electro-galvanised, approx. 20 µm

Finish treatment: Passivated



Wire guards for inlet and outlet

ANTI-VIBRATION MOUNTINGS

The CND and CNF are available with anti-vibration mountings.

Refer to the installation instructions for location and choice of anti-vibration mountings.



Anti-vibration mountings

BASE PLATE FOR ANTI-VIBRATION MOUNTINGS

The CND and CNF are available with base plates for fixing anti-vibration mountings to the foundation.

Material: Domex 240

Surface treatment: Hot-dip galvanised, approx. 60 µm

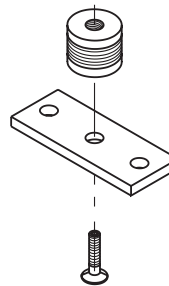

Base plate for anti-vibration mountings

INSPECTION DOORS

The CND and CNF are available with inspection doors located in the scroll casing.

Inspection doors are available in 2 sizes and depend on fan size.

Please state the location of the inspection door in relation to the outlet direction on order.

Material: Domex 240

Surface treatment: Hot-dip galvanised, approx. 60 µm

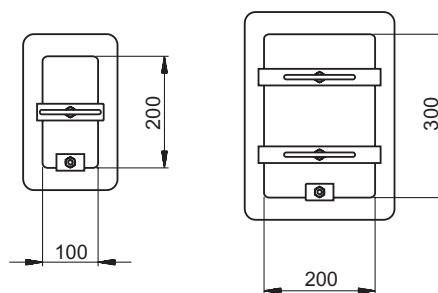

Inspection and access doors

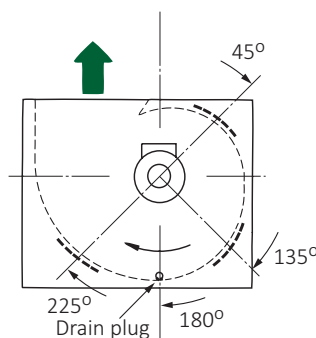

Possible positions of inspection door

DRAIN PLUG

The location of the drain plug in the fan casing side plates must be stated on order. The position is in relation to the outlet direction.

Material: Stainless steel and hot-dip galvanised fittings respectively

Connection: 3/4" RG

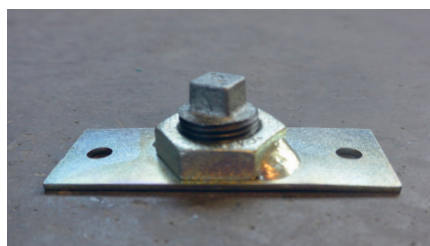

Drain plug

BRASS OR COPPER INLET CONES

Inlet cones made of brass or copper for use in environments with increased safety is available for CND and CNF.

Material: Half-hard brass or copper



Brass inlet cones

SOUND CONDITIONS

Fans in operation generate sound. It is partly electrical and also mechanical sounds from the motor, bearings and other mechanical parts. Sound from airflows through the fan add to the sound picture as well.

The sound generation is minimised by careful design and production of fan parts. In particular the inlet cone and impeller, which contribute greatly to the overall sound generation. Poor installation conditions, for example a sharp duct bend immediately before the inlet opening, may add considerably to the sound generation.

Electrical and mechanical generated sounds and the part of sound from the airflow that passes out through the fan casing, can only be dampened by enclosing the fan in a casing or with walls of low-vibration materials.

Sound generated in the impeller spreads through the inlet and outlet openings to the duct system and on to the ventilated rooms. Calculation of the sound conditions in the duct system and the ventilated rooms, including dimensioning of any silencers in the system, is only possible on the basis of the sound power level in the fan inlet and outlet openings. A sharp distinction must be made between the terms sound power level and sound pressure level.

Sound power level expresses the energy

emitted through the fan inlet and outlet openings and forms the basis for any calculation concerning the sound conditions in the connected duct systems and in the rooms served by the fan.

Sound pressure level is a measure of the sound impression perceived by the ear at a given location in the environment. It can be measured using a sound meter with a microphone mounted in location.

Sound pressure level depends on the fan sound power level, the distance from the fan and the silencing properties of the environment. When the fan sound properties are characterised by stating a sound pressure level, it is necessary also to give a precise description of the conditions under which the stated sound level occurs. When comparing the sound properties of two fans, make sure not to compare the sound power level with the sound pressure level. Do only compare sound pressure levels with the same distances from the fan and with the same silencing in the environment.

For a correctly designed fan, the sound power level depends primarily on the supplied airflow rate and the total fan pressure. It can be read on the graphs for the individual fans in section "Dimensioning charts" beginning on page 4.

The sound power level is stated in dB with a reference value of 10-12 W, and applies

within the normal working range of the fan. The tolerance is ±5 dB. If the sound power level needs to be divided into octave values, the sound power level in the different octave bands is determined by deducting the correction values in the table below from the total sound power level found.

The correction values depend on the blade frequency.

$$z \times \frac{n}{60}, \text{ where}$$

z = number of blades
n = fan speed in RPM

The CND and CNF have 8 blades each.

Example

A centrifugal fan of type CND-500 has an output of 3 m³/s at 1600 Pa and 2323 RPM.

Blade frequency

$$8 \times \frac{2323}{60} = 310 \text{ Hz}$$

In the chart on page 6, the total sound power level is 100 dB.

The correction value for 250 Hz is 4 dB.

The sound power level for this octave band is thus 100 dB - 4 dB = 96 dB

The full octave analysis is shown in the below table.

Blade frequency [Hz]	Octave band [Hz]							
	63	125	250	500	1k	2k	4k	8k
90-180	7	4	7	12	17	22	27	32
180-360	11	7	4	7	12	17	22	27
360-710	13	11	7	4	7	12	17	22
710-1400	15	13	10	6	4	7	12	18
	63	125	250	500	1k	2k	4k	8k
Example	89	93	96	93	88	83	78	73

Sound power levels

REGULATION OF AIRFLOW RATE

The fan capacity can be regulated in several ways, depending on the operating requirements.

REGULATION METHODS

- By changing poles between 2 fixed RPMs in the ratio 3: 2 (motor with 2 separate windings) or 2:1 (Dahlander winding motor)
- By frequency regulation
- By a combination of the above

CHANGING POLES

In connection with time-related variations in the air-flow rate demand, for example night-time and daytime operation, it is recommended that the fan is fitted with a change-pole motor. When the fan is changed to a different RPM, the fan efficiency is unchanged.

The change can be timer-controlled. If other operating points are required, than can be achieved by changing poles, other regulation methods must be used.

FREQUENCY REGULATION

Fan efficiency remains virtually unchanged throughout the regulation range and no sound is generated as a result of the regulation.

QUALITY AND SERVICE



REST ASSURED

The Novenco CND-CNF centrifugal fans are produced in accordance with Novencos well-known quality standards. Novenco is ISO certified and all fans are inspected and tested, before leaving the production.

The fans are offered with options for

IMPORTANT

This document is provided 'as is'. Novenco Building & Industry A/S reserves the right to changes without further notice due to continuous product development.

Pictures in the catalogue may show products with accessories fitted.

The fans are designed for continuous operation. The following kinds of operation may cause fatigue break in the impellers and endanger people.

- Operation in stall area
- Operation with pulsating counter pressure – called pump mode
- Daily operation with exceedingly starting and stopping

If in doubt, Novenco should be contacted to assess the suitability of the fans.

Copyright (c) 2009- 2020,
Novenco Building & Industry A/S,
All rights are reserved.

technical guidance on installation, test of function and training of personnel.

WARRANTY

Novenco provides according to law a standard 12 months warranty from the product is sent from the factory. The warranty covers materials and manufacturing defects.

PATENTS AND TRADEMARKS

Novenco®, 诺文科, 诺万科 and 诺克 are registered trademarks of Novenco Marine & Offshore A/S. ZerAx® is a registered trademark of Novenco Building & Industry A/S. AirBox™, NoVa™ and NovAx™ are trademarks of Novenco Building & Industry A/S.

Other trademarks appearing in this document are the property of their respective owners.

Wear parts are not covered.

Extended warranties can be agreed upon.

QUALITY AND ENVIRONMENT

Novenco Building & Industry A/S is certified in accordance with ISO 9001 and 14001.



All Novenco Building & Industry's products are designed, developed and manufactured in Denmark.



Pure competence in air.

MU 16048 1120

Building & Industry

NOVENCO 

SCHAKO Group

WWW.NOVENCO-BUILDING.COM